

# MIDLAND®



OWNER'S MANUAL

# ALAN 100 PLUS

# CONTENTS

Features.....	pag.	1
Installation.....	pagg.	1, 2
Replacing fuse.....	pag.	3
Antenna system.....	pag.	3
Mobile antennas.....	pagg.	3, 4
Base station antenna.....	pag.	4
Microphone connection.....	pag.	4
Using the transceiver.....	pag.	5
To receive.....	pag.	5
To transmit.....	pag.	5
Remote speaker operation.....	pag.	5
Technical specifications.....	pag.	6

## FEATURES

- Phase Locked Loop circuitry gives precise frequency control and stability over all 40 channels: pinpoint channel tuning accuracy with separate scan up and down controls.
- Ceramic filters give superior selectivity and freedom from adjacent channel interference.
- Green Led channel indicator clearly shows which channel is activated.
- Red Led (TX) and Green Led (RX) show the operative modality: TX= transmission; RX= reception.
- Hysteresis-type Squelch circuit automatically compensates for signal fading to eliminate signal "chopping" during message reception.
- Extremely sensitive.
- Condenser type plug-in communications microphone provides superior transmission.
- Emergency switch lets you switch to channel 9 or 19 - instantly.
- Jacks for external speaker let you hook up other speaker systems.
- Works with negative ground 12 - 13.8 V DC.

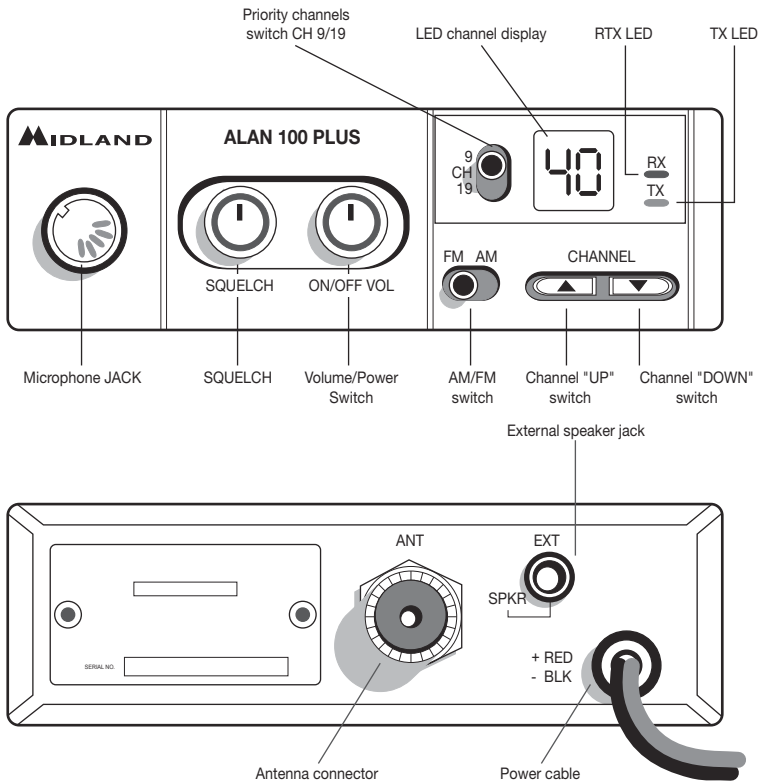

## INSTALLATION

Safety and convenience are the primary consideration for mounting any piece of mobile equipment. All controls must be readily available to the operator without interfering with the movements necessary for safe operation of the vehicle. Be sure all cables are clear of the brake, clutch and accelerator. Also, thought must be given to the convenience and comfort of passengers (for example, will they have adequate leg room?).

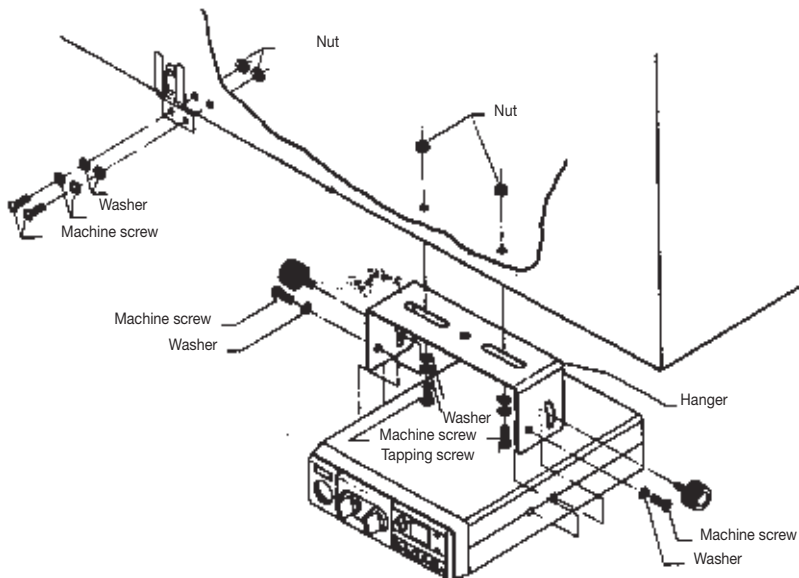

Another extremely important requirement is the ease of installation and removal for those occasions when you might want to remove the unit for service and maintenance. The most common mounting position for a Transceiver is under the dashboard directly over the drive shaft hump. Do not mount the Transceiver in the path of the heater or air conditioning air stream. Take your time and plan your installation carefully. When you have determined the best location for mounting, use the mounting bracket as a template to mark mounting holes. Take care when you drill the holes that you do not drill into wiring, trim or other accessories.

Mount in position with bolts, lock washers and nuts or self-threading screws. You can install this Transceiver in any location where 12-13.8 V DC power is available. It can be connected to negative ground system. Just be sure you connect the RED wire to the (+) terminal and the BLACK wire to the (-) terminal.

Connect the RED wire (with in-line fuse holder) to the accessory terminal on the ignition switch of your vehicle. Make a good mechanical and electrical connection to the frame of the vehicle for the black wire.

You can use an auto accessory lighter plug, available on the CB market, to connect your Transceiver to the vehicle's cigarette lighter receptacle. However, it is better to connect the DC power cord directly to the accessory terminal of the ignition switch. This will prevent unauthorized use of the Transceiver, and will also prevent you from leaving it on unintentionally. Before operation, you must install and connect your antenna system. The lead from the antenna you've installed should be connected to the antenna coaxial connector. If you are using an external speaker, connect it to the EXT-SPKR jack.

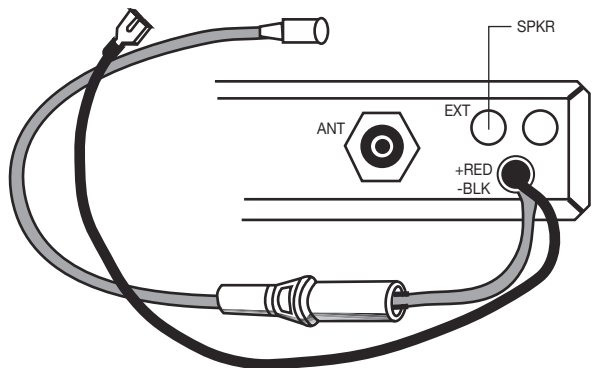

## REPLACING FUSE

If you replace the fuse for DC Power Cord, use 2 A type (one supplied as spare). Hold the fuse holder and press on the inside, then rotate the holder.

## ANTENNA SYSTEM

A mobile antenna system is not limited to just the antenna. The transmission line as well as the vehicle are important factors in the total antenna system. Therefore, you must use the correct type of transmission line and mount the antenna securely in a position that will give you optimal results. Use coaxial cable with an impedance of 50 Ohms. We suggest type RG 58/U for lengths under 2.5 m or RG 8/U for longer lengths. Generally speaking, you should keep the length of the transmission line to a minimum.

The above discussion is as important for reception as it is for the transmission. If a mismatch exists between the antenna and the receiver, the excellent sensitivity and signal-to-noise ratio of the receiver circuit will be defeated.

## MOBILE ANTENNAS

A few general rules should help you to install any mobile antenna properly.

- Keep it as far as possible from the main bulk of the vehicle.
- During operation, it must be vertical, and rigid enough to remain vertical when the vehicle or boat is in motion.
- Mount it as far as possible from sources of noise (ignition system, gauges, etc.) and keep the transmission line away from these noise sources.
- An antenna mounted in a boat requires a good ground connection. This can be either a metal hull or a ground made of tin-foil or copper sheeting. This ground should cover an area of at least 1 m<sup>2</sup> or more. Be sure the Transceiver also has an adequate ground. There are many types of mobile CB antennas: a full quarter-wave length whip, a center-loaded whip, top loaded whip and the base loaded type are typical.

A vertically polarized whip antenna is best suited for mobile service. It is omni-directional. If it's the loaded type, you will find it a physically shorter antenna. But, for greater efficiency the 2.5 m long, full quarter-wave whip is better. Antenna length is directly related to efficiency. Generally, the longer it is the more efficient.

There are many possible antenna locations on a car. Four of the most popular are shown and discussed on the following.

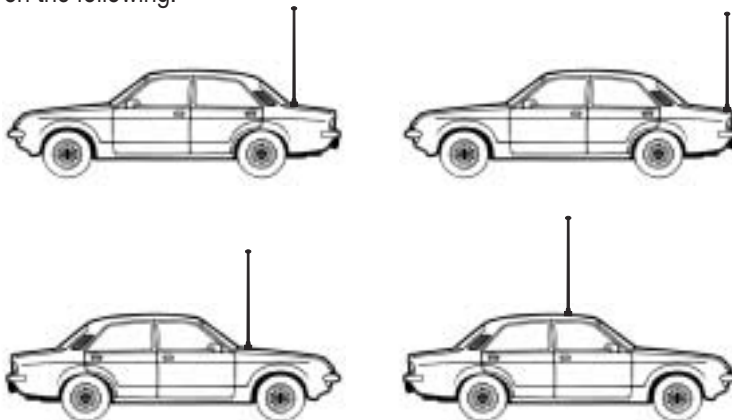

**Roof Mount** - In this position the antenna radiates equally in all directions. Since the normal 1/4 wavelength whip antenna is too long for roof mounting on a vehicle, the antenna is shortened and loading coil is used to provide the proper electrical length. Our fiberglass roof mount is a good durable antenna.

**Front Cowl Mount** - The radiation pattern is slightly greater in the direction of the rear fender opposite the side on which the antenna is mounted. However, the front position offers a number of advantages. The CB antenna can be easily mounted. It can double as both the CB and the standard auto radio antenna by employing a two-way coupler. Ask about our complete line of antennas.

**Rear Deck Mount** - The radiation pattern is stronger in the direction of the front fender opposite the side on which the antenna is mounted. In this position you can use a full quarter-wave antenna or a shorter loaded whip. Here you might consider one of the full 2.5 meters whips.

**Bumper Mount** - The antenna radiates in a pattern directly in front of and to the rear of the vehicle, with maximum radiation directly away from the vehicle, in a horizontal plane. Despite its fairly irregular pattern, a bumpermounted full-length whip antenna will normally give the best results. Removing the antenna is simple and will leave no holes in the car.

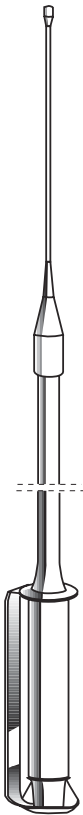

## BASE STATION ANTENNA

While your Transceiver is designed for mobile operation, you might wish to use it as a base station unit, in conjunction with a 12 - 13.8 V 2 A DC power supply. If you decide to use your Transceiver as a base station, choose an antenna designed to operate most efficiently as a base station antenna. For example, the 1/2 wave antenna is a high-efficiency radiator with omnidirectional characteristics. It performs as well in most applications as does the ground plane. You can use this type of antenna for medium-long range communications.

**WARNING:** When you install or remove a base station CB antenna, use extreme caution. If the antenna starts to fall, let it go! It could contact overhead power lines. If the antenna touches the power line, any contact with the antenna, mast, cable or guy wires can cause electrocution and death! Call the power company to remove the antenna. Do not attempt to do so by yourself!

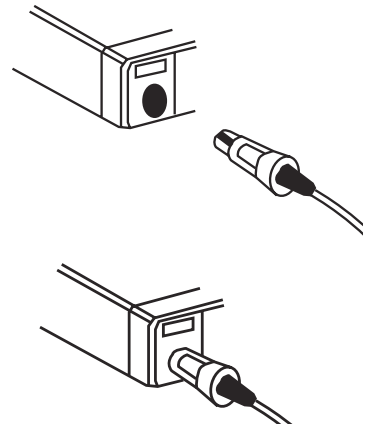

## CONNECTING THE MICROPHONE

Your Transceiver has a new microphone connector. This ensures that you won't accidentally pull out or loosen the plug connection when moving the microphone cable out. To connect the microphone plug: press the small tab on the side and insert plug into jack, taking care to align the plug and jack properly. To release the microphone plug: press the small tab on the side, then push the plug in to release the lock and pull the plug out.

## USING YOUR TRANSCEIVER

Do not transmit without a suitable antenna or 50 Ohm load connected to the antenna connector.

### To receive:

1. Check that the unit is properly connected to a source of 12-13.8 V through the in-line fuse and red wire.
2. Make sure that the antenna is attached.
3. Connect the mic plug to the mic jack.
4. Select AM or FM mode.
5. Set the emergency switch to the center position.
6. Set the Squelch control to maximum counterclockwise position.
7. Turn on the unit by rotating the VOLUME control clockwise.
8. Set channel selector to the desired channel.
9. Adjust VOLUME for a suitable listening level.
10. Adjust Squelch to cut out annoying background noise when no signal is being received. To do this, set the Channel Selector to a channel where no signals are present or wait until signals cease on your channel. Then, rotate the Squelch control in a clockwise direction to the point where the background noise just stops. Now, when a signal is present, you will hear it, but will not be disturbed by noise on the channel between signals. When properly set, the Squelch keeps the receiver "dead" until a signal comes in on that channel. However, do not set the Squelch too high, or weak signals will not be able to open the Squelch circuit. To receive very weak signals, it is best to leave Squelch set to the minimum position by rotating the control maximum counterclockwise. The Squelch circuit in your Transceiver is an advanced design. It uses an operational amp IC to accomplish a hysteresis action. The result is that when you set the Squelch for a precise signal level, if that signal level increases or decreases in strength, the Squelch circuit will follow this change. With conventional Squelch circuit, often a signal which changes strength get "chopped" by the Squelch circuit and you lose a portion of the message. With a hysteresis Squelch, you get it all.

### To Transmit:

1. Select the desired channel.
2. Press the push-to-talk button on the microphone and hold it an angle about 5-7 cm from your mouth and speak in a normal voice.
3. To receive, release the push-to-talk button.

Be sure the mic plug is firmly connected to the jack.

**NOTE:** shouting into the mic will not increase your power or signal. An internal circuit automatically sets the mic signal for maximum modulation, so speak loudly will give no advantage.

## REMOTE SPEAKER OPERATION

An 4 Ohm speaker, rated at 3-10 watts, should be used for this function. Plug the speaker into the EXT SPKR jack at the rear of the Transceiver. When the external speaker is plugged in, the internal speaker is disconnected. You can now monitor all incoming signals through your remote speaker.

# TECHNICAL SPECIFICATIONS

## RECEIVER

Frequency coverage.....	<b>26.965 to 27.405 MHz</b>
Sensitivity.....	<b>1.0 <math>\mu</math>V or better for 20 dB SINAD</b>
Adjacent Channel Rejection.....	<b>60 dB at 10 kHz; 70 dB for 20 KHz</b>
Intermediate Frequency.....	<b>1st IF=10.695 MHz; 2nd IF=455 KHz</b>
Audio Output power.....	<b>4.5 watts max</b>
Frequency Response (-6dB).....	<b>450-2500 Hz</b>
Cross Modulation.....	<b>45 dB or better</b>
Squelch.....	<b>adjustable from 1.2 <math>\mu</math>V to 1mV</b>

## TRASMITTER

Frequency coverage.....	<b>26.965 to 27.405 MHz</b>
Output Power.....	<b>4 watts max</b>
Type of modulation.....	<b>AM/FM</b>
Max Deviation.....	<b>2.5 KHz FM; 90% AM</b>
Spurious Radiation.....	<b>62 dB or better</b>
Frequency Tolerance.....	<b>better than 0.002%</b>
Antenna impedance.....	<b>50 Ohm</b>
Power supply.....	<b>13.8V</b>
Current Drain.....	<b>FM: 1.3A; AM: 2A</b>
Dimensions.....	<b>124x38x190 mm</b>
Weight.....	<b>1.2 kg</b>